



PART #: GLS-SIM
DESCRIPTION: GLS-SIM WITH GLA-KS KEYSWITCH WIRING DETAL

REVISION: 001

DATE: 3/18/16

NOTES:



15 Volvo Drive
Rockleigh NJ 07647
Tel: 888-273-7876
Fax: 201-767-6011
www.crestron.com

PART #:
GLS-SIM WITH
GLA-KS KEYSWITCH
DRAWING:

NOTES KEY

- ① (2) ROTARY DIP SWITCHES; USED FOR MANUALLY SETTING THE CRESNET ID; '00' SETTING ENABLES TOUCH-SETTABLE ID.
- ② (1) 4-POSITION DIP SWITCH; SETS SENSOR TYPE AND OPERATING MODE. SEE CHART BELOW FOR SETTINGS.
- ③ (1) MINIATURE PUSHBUTTON, USED FOR TOUCH SETTABLE ID.
- ④ **PWR:** (1) GREEN LED, ILLUMINATES WHEN DC POWER IS APPLIED TO THE NET PORT
- ④ **NET:** (1) YELLOW LED, INDICATES COMMUNICATION WITH CONTROL PROCESSOR
- ⑤ CRESNET NETWORK CONNECTOR TO CONTROL PROCESSOR OR ADDITIONAL MODULES. FACTORY BUILT CABINETS WILL HAVE CRESNET CONNECTIONS WIRED IN FACTORY.
- ⑥ (1) 4-PIN 3.5MM DETACHABLE TERMINAL BLOCK; SENSOR INPUT COMPRISED OF 24VDC POWER OUTPUT AND
- (2) DIGITAL OR ANALOG INPUT PORTS;
- DIGITAL INPUT: RATED FOR 0-24 VOLTS DC, INPUT IMPEDANCE 20k OHMS, LOGIC THRESHOLD 1.25 VOLTS DC;
- ANALOG INPUT: RATED FOR 0-10 VOLTS DC, PROTECTED TO 24 VOLTS DC MAXIMUM, INPUT IMPEDANCE 20k OHMS; PROGRAMMABLE 5 VOLTS, 2k OHMS PULL-UP RESISTOR PER PIN; MAXIMUM POWER LOAD: 1 AMP @ 24 VOLTS DC.
- ⑦ DECORA-STYLE FACEPLATE (F.B.O)
- ⑧ KEYSWITCH SUB-ASSEMBLY. UNIT IS PROVIDED WHITE BY DEFAULT. UNIT IS AVAILABLE IN BLACK WITH ADDITIONAL LEAD TIME- CONTACT CRESTRON FOR AVAILABILITY.
- ⑨ INDICATOR LED. LED WILL GLOW DIMLY AS A "FINDER" AT ALL TIMES, AND ILLUMINATE AT FULL INTENSITY WHEN KEYSWITCH IS SET TO "ON"
- ⑩ MOMENTARY KEYSWITCH
- ⑪ KEYSWITCH TERMINALS (ON REAR OF KEYSWITCH ASSEMBLY). ACCEPT WIRES 18-24 AWG.

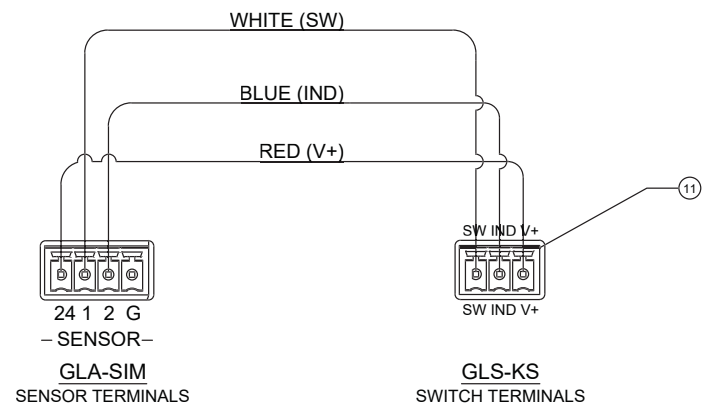
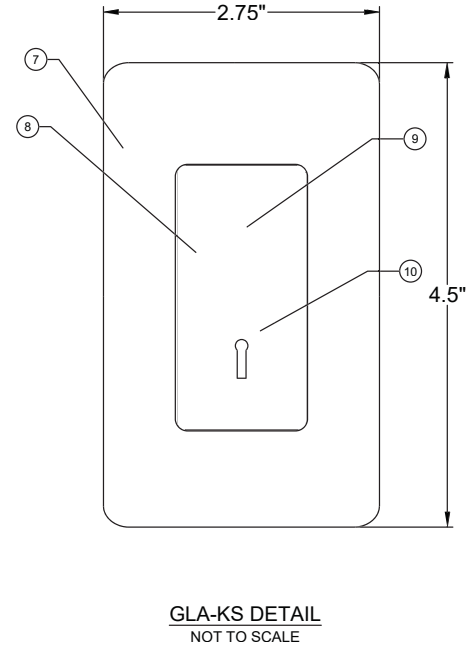
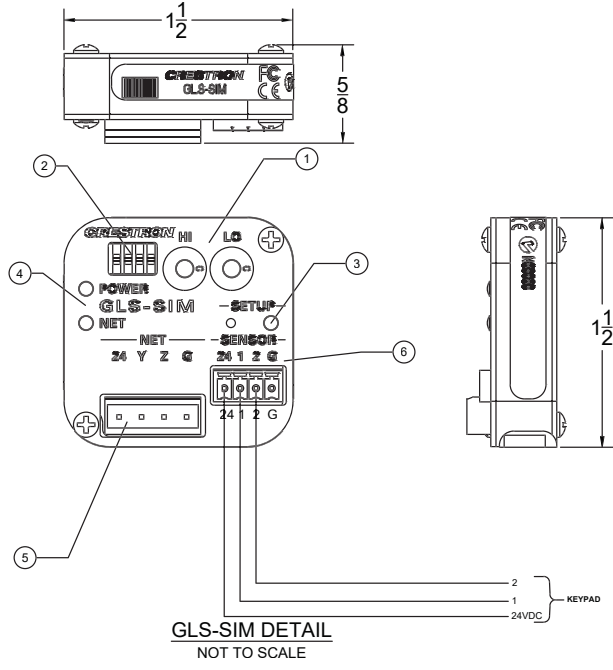

| DIP SWITCH SETTINGS | | |
|---------------------|------------|-------------|
| SENSOR INPUT | DIP SWITCH | WITH GLA-KS |
| 1 | 1 | ON |
| | 2 | ON |
| 2 | 3 | ON |
| | 4 | OFF |

